

NS87

Engine Power: SAE J1995, gross	62 KW (85HP) @ 1,600 rpm
Operational Weight :	3,050KG (6725 lb) STD
Bucket capacity(SAE) :	0.52 m ³



* ENGINE

• Model	Kubota V3600
• Number of cylinders	4 cylinder in line
• Cooling type	Water cooling diesel
• Maximum power	63KW (84.5HP)/2600rpm
• Maximum torque	84.5HP/2600rpm
• Piston displacement	3620cc
• Bore & stroke	98mm*113mm
• Starter	Electric motor
• Batteries	98mm / 120mm
• Compression ratio	18.5

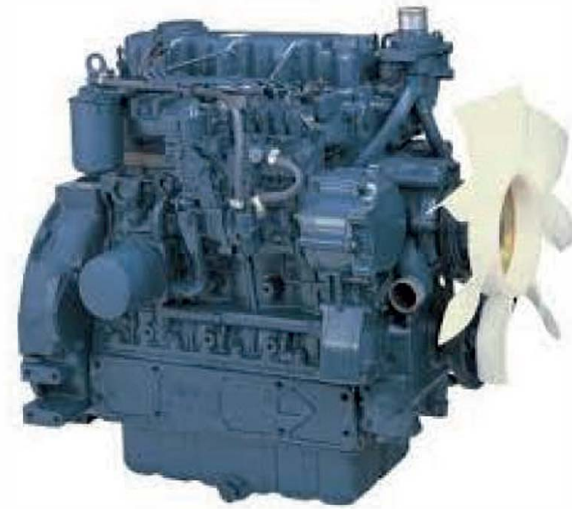

* HYDRAULIC SYSTEM

• Hydraulic pump capacity	Rexroth pump
• Hydraulic motor	40.6 cc / rev
• Hydraulic motor capacity	VIS motor
• Lift cylinder	400 cc/rev
• Tilt cylinder	75*40*612ST*85oL
• Cycle times	65*35*44ST*708L
	Lift raising time 4.3 sec
	Lift lowering time 3.0 sec
	Tilt dumping time 2.2 sec
	Tilt rollback time 1.5 sec
• Aux.pump	25.4 cc
• Operating pressure	200 bar

* REFILL CAPACITIES

Fuel tank	: 53ℓ
Cooling system	: 16ℓ
Engine oil	: 8ℓ
Chain case	: 40ℓ
Hydraulic system	: 67ℓ



Simple and convenient open and close design for Operator and Rear Door maintenance



simple attachment system lets you switch from a bucket to a sweeper or to a dozer .blade in seconds

Equipped cabin the door Hydraulic Ride Control

DIMENSIONS

Configuration		NS87
Overall Operating Height (to top of)	A	3,975mm
Overall Operating Height (to hinge pin)	B	3,045mm
Overall Height	C	2,062mm
Overall Length	D	3,398mm
Overall Length (without bucket)	E	2,651mm
Overall Width	F	1,886mm
Tread Width	G	1,384mm
Wheel Base	H	1,100
Ground Clearance	J	214mm
Dump Angle	K	40 degree
Dump Height	L	2,330
Dump Reach	M	888mm
Rollback at Ground	N	27 degree
Turn Circle Front (without bucket)	Q	1,307mm
Turn Circle Front (with bucket)	R	2,112mm
Turn Circle Rear	S	1,504mm
Overall Width (without bucket)	T	1,708mm
Departure Angle	U	25 degree

Performance

Rated Operating	1,220 kg
Capacity Tipping Load	2,440 kg
Operating Weight	3,050 kg
Travel Speed	11 km/h
Bucket Capacity (heaped)	0.52m ³
Drive	4 wheel drive
Tire	12.00 * 16.5

Measured to the tip of the bucket teeth or bolt-on edges.

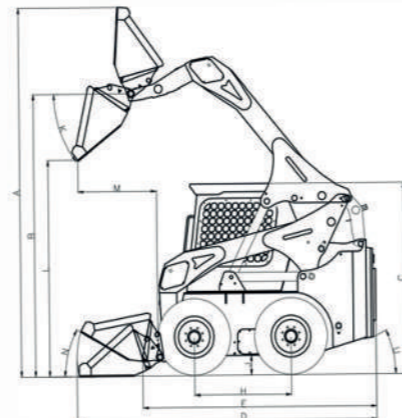
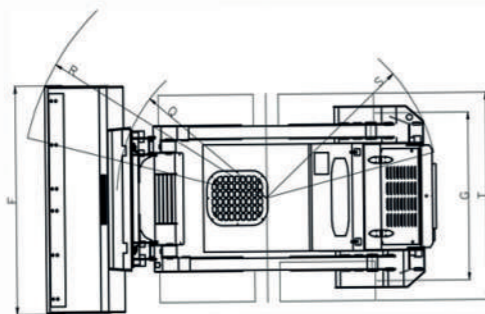

ATTACHMENTS

NS87



PALLET FORKS



BREAKER



SWEEPER BUCKET



MIXING BUCKET



Powered by
Innovation

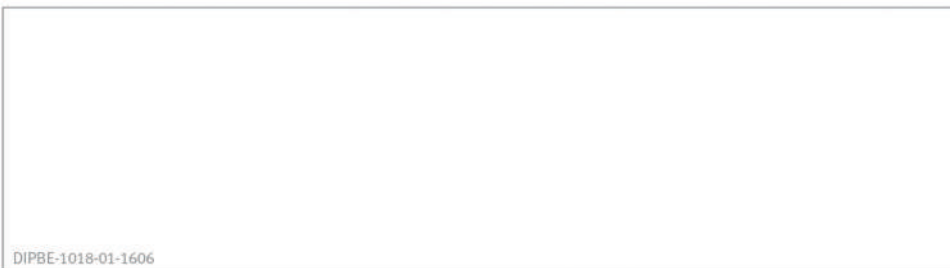

DIPBE-1018-01-1606

NASR MACHINE
INTERNATIONAL

www.nasrmachine.com
sales@nasrmachine.com
+98 (21) 61777
Whatsapp : +98 (912) 30 430 86

