

Construction Equipment

FR510E2



TECHNICAL SPECIFICATIONS



Engine

Engine Model	CUMMINS QSM11
Number of Cylinders	6
Max. Torque/Speed	1898N·m/1400rpm
Displacement	10.8L



Hydraulic system

Max. Main Pump Flow	760L/min
Main Safety Valve Pressure	34.3MPa



Main Performance

Bucket Digging Force	310kN
Arm Digging Force	260kN
Max. Traction Force	382kN
Max. Walking Speed	4.6km/h
Min. Walking Speed	2.9km/h
Rotary Speed	7.8r/min
Gradeability	35°
Ground Pressure	83kPa



Oil Capacity

Fuel Tank	670L
Hydraulic Tank	370L
Engine Oil	38L



NASR CONSTRUCTION MACHINERY GROUP CO., LTD.

As manufacturer, NASR has right to constantly upgrade and improve our products without informing to customers. The pictures in literatures are for reference only, the detailed specifications are subject to real products.



RELIABILITY

Advanced Technology

First-user of function-relief cushion valve system in industry, machine's respond could keep the same speed even in the extreme cold weather. On the premise of keeping the optimal impact pressure, the starting or switching of working device without any postpone, that makes smooth, efficient and energy-saving operation of machine and reaches to leading level of industry.

Powerful Engine

The new generation of CUMMINS QSM11 engine originally imported from America which is specially designed for mining applications. Its exclusive PT fuel control and injection technology delivers higher precise and full efficient traits compared to traditional electric controlled high-pressure common rail technology.

Electric Control Positive Flow System

During the design stage, NASR has utilized the latest technologies to develop an integrated hydraulic system. The positive flow control system adjusts the displacement of pump and the motion of valve spool simultaneously, delivering optimal operating experience for the operator with smooth and responsive control.

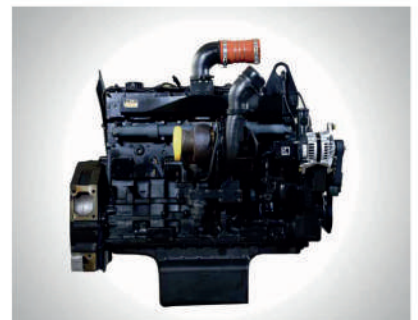



PRODUCTIVITY

Superb Match

Each component in powertrain system, such as engine, gear, rotary motor, working pumps and hydraulic cylinder are specially customized to achieve perfect match with one another, the whole system features are more reliable.

Great Digging Force

On the premise of ensuring static digging force, NASR dedicate to research of dynamic digging force. The system will automatically detect the pressure when face big frustration during digging, and automatically adjust output pressure to keep the powerful force in digging process.

Larger Bucket

Equipped with larger bucket which is specially designed to achieve maximum productivity and durability. The unique shape design improves the bucket's stability when doing loading job. Applying with latest technology and optimal hydraulic system, it has good performance on fuel consumption.

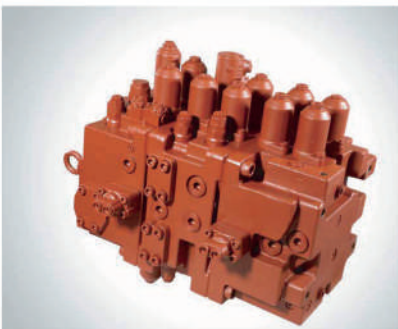
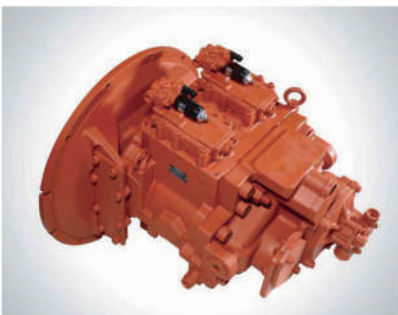

ROBUSTNESS



Rigorous Test and Experiment

Machine test: NASR CL-6 machine testing yard covers more than 200,000 square meters, it can simulate various applications like earthmoving, aggregate, sand, quarry and forth. The test including strengthen vibration, noise, working efficiency, oil consumption, travel and climbing tests, etc. Every new model should go through more than 2,000 working hours strengthen combination test here.

Robust Chassis

Reinforcement of Track Roller, Carrier Roller, Idler, Drive Roller and Track makes brace capacity increase dramatically which can also working in the temperature of -45°C. The crawl tracks are made of high-strength anti-wear steel, with great grip on ground.

Reinforced Working Device

Adopts high-strength rock bucket teeth which is special suitable for the tough applications, the boom and arm are reinforced to prolong the service life. Self-lubrication shaft sleeve is used to make every linkage works smoothly with high durability.

COMFORT



Large Spacious Cab

Equipped with spacious cab which provides operator large space to operate machine. The premium suspension seat with armrests is very comfortable and it can reduce the working fatigue dramatically. Front windshield can be partially or fully retracted to the cab roof. Rearview camera is optional to get better rear vision in order to improve operation safety in jobsite.

Ergonomic Design

The proportional joystick delivers sensitivity, accuracy and smoothness during operation. This joystick is specially designed to meet different operating conditions. Intelligent control system is standard which could control diverse attachments such as bucket, hammer, scarifier and hydraulic scissors.

Low Noise and Low Vibration

In order to reduce work fatigue and improve productivity, the noise inside of cab has been controlled to the lowest level. The cab is attached to the frame with buffer that dampens vibrations and sound levels to enhance operator comfort.

INCREASE YOUR PRODUCTIVITY AND PROFIT WITH NASR ATTACHMENTS

You can easily expand the performance of your machine by utilizing any of the variety of NASR Attachments.

Each NASR Attachments is designed to fit the weight and horsepower of NASR Excavator for improved performance, safety, and stability.



Hydraulic Hammer



Scarifier



Standard Bucket



STANDARD CONFIGURATION

Engine

Turbocharged, 6-cylinders, water-cooling, direct injection

Radiator with protective fence

Oil bath type cleaner

Air intake heater

Fan guard

Double filters, dry air filter

Engine oil pan with oil drain valve

Automatic idle speed system

Three-stage fuel filter

75A/24V alternator

Cab

Ashtray

Cigarette lighter

Seat belt

Shade plate

Storage compartment

Emergency hammer

Air conditioner

Audio speaker

Shock absorber

Flexible aerial

Radio

Hydraulic safety locking rod

Sun proof safety glass

Cab floor mat

Pull-up front window

Dismountable lower windshield

Sun shade window

Windshield wiper

Skylight window

Suspended seat

Big storage area

Chassis

Fixed chassis

600mm double tooth track plate

Hydraulic System

Automatic hydraulic system (flow confluence system)

Multistage filtration system

Anti-sway valve

Boom and stick locking valve

Cylinder buffer device

Anti-slope turning device

Waste oil drainage pipeline

Pilot buffer valve (rotary, stick, boom)

Dual-speed travel motor

Hydraulic hammer pipeline

Electronic Control System

24V power battery

Monitor brightness adjustment

Maintenance tips

Safe stop & start function

Master switch

Engine start protection

Multilingual display

Cab ceiling light

Diagnostic interface

Emergency stop switch

Automatic diagnosis system

Automatic idle speed system

One-touch pressure enhancement

Anti-theft system

Swing Platform

Toolbox

Large pedal

Large handrail

Bottom guard plate

Anti-crash beams

Anti-skid plates

Passage with handrails

TECHNICAL SPECIFICATIONS

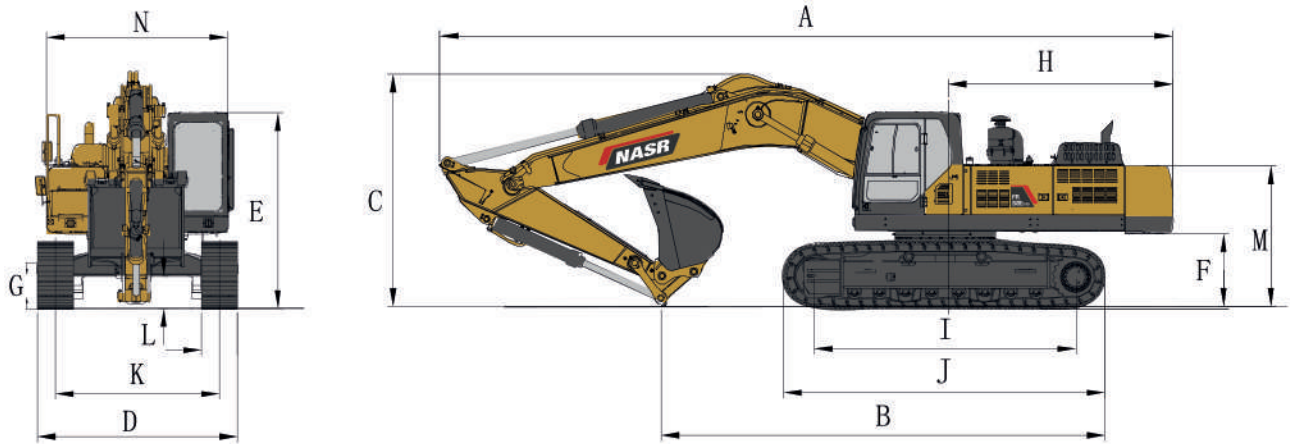

Working Range

Max. Digging Height	1	10620mm
Max. Dumping Height	2	7443mm
Max. Digging Depth	3	7282mm
Max. Vertical Digging Depth	4	6220mm
Max. Digging Radius	5	11520mm
Max. Ground Digging Radius	6	11306mm
Min. Turning Radius	7	4962mm

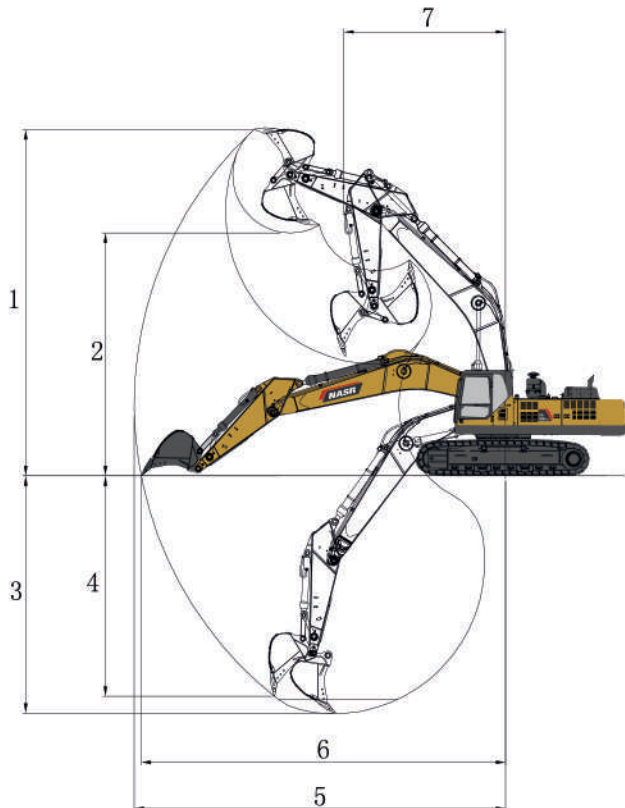

Dimensions

Shipping Length	A	12253mm
Shipping Ground Length	B	7398mm
Boom Height	C	3900mm
Shipping Width	D	3340mm
Cab Height	E	3900mm
Ground Clearance of Counter Weight	F	1237mm
Min. Ground Clearance	G	550mm
Tail Turning Radius	H	3800mm
Wheel Tread	I	4370mm
Track Length	J	5357mm
Track Gauge	K	2740mm
Track Shoe Width	L	600mm
Hood Height	M	2348mm
Rotary Platform Width	N	3340mm

Other Specifications

Boom Length	7060mm
Arm Length	2900mm
Track Section Number (each side)	49
Track Roller Number	9

Certain specification(s) are based on engineering calculations and are not actual measurements. Specification(s) are provided for comparison purposes only and are subject to change without notice. Specification(s) for your individual Doosan equipment will vary based on normal variations in design, manufacturing, operating conditions, and other factors. Pictures of Doosan units may show other than standard equipment.

Powered by Innovation

نصر ماتي
شركة بين العالبي (سهامتي خاص)



www.nasrmachine.com
sales@nasrmachine.com
+98 (21) 61777
Whatsapp : +98 (912) 30 430 86